

| LOC | | DIST | | REVISIONS | | | | DATE | APPD |
|------|-----|-------------|---|-----------|--------------------------------|---------|------|------|------|
| ZONE | LTR | DESCRIPTION | | DATE | APPD | | | | |
| G | 14 | P | F | C | REV & REDRAWN PER 0720-0040-93 | 3-17-93 | APPD | | |

METRIC
 DIMENSIONS LISTED IN mm [INCHES]

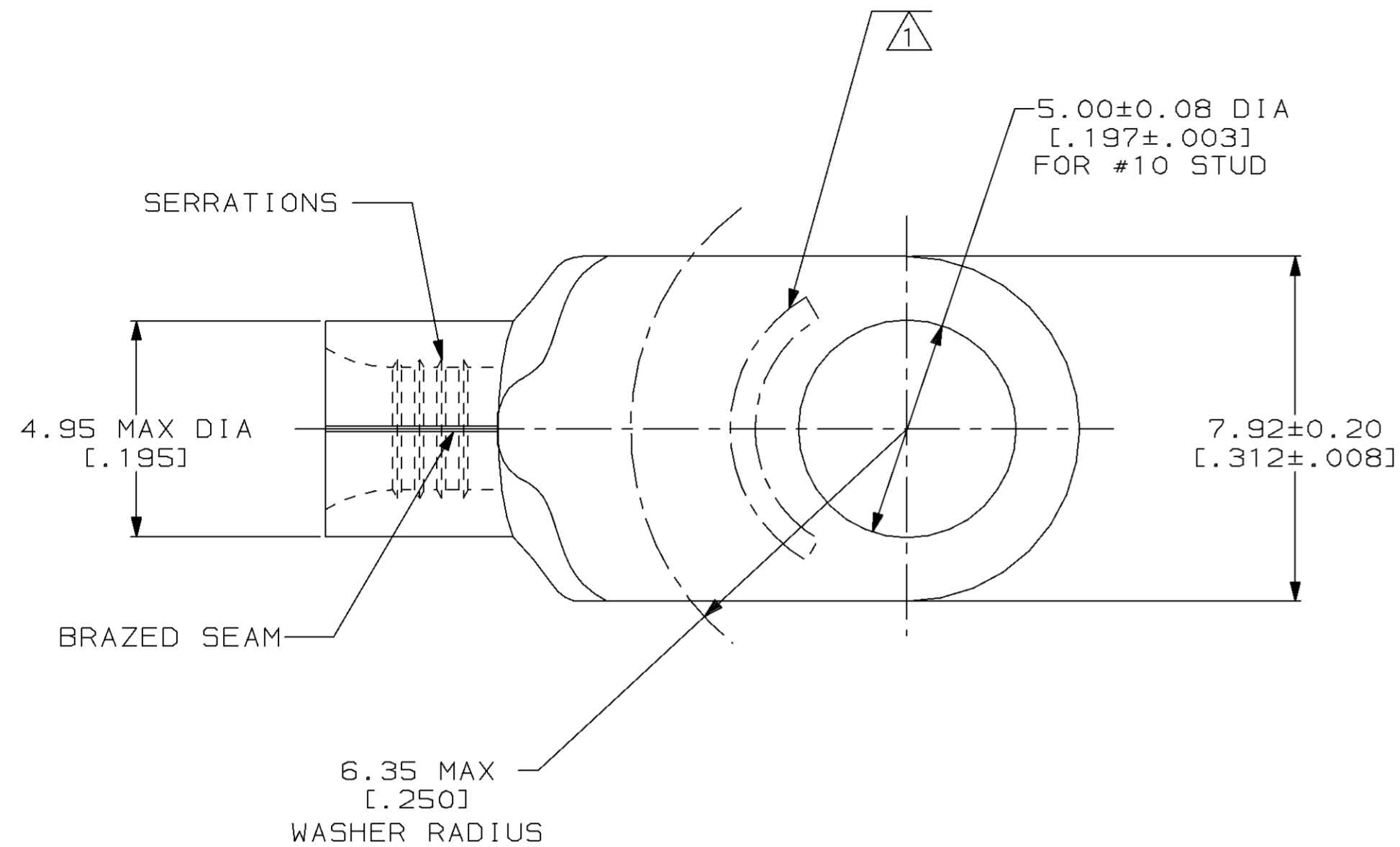

| | |
|--------------------------------|----------------------------|
| AMP WIRE RANGE | UL E13288 Listed |
| 14-12 AWG SOLID OR STRANDED | 14-12 AWG STRANDED |
| SR LR7189 Certified | MILITARY P/N AND CLASS |
| 14-12 AWG SOLID OR STRANDED | NOT APPLICABLE |

△ STAMP AMP 14-12* APPROX AS SHOWN

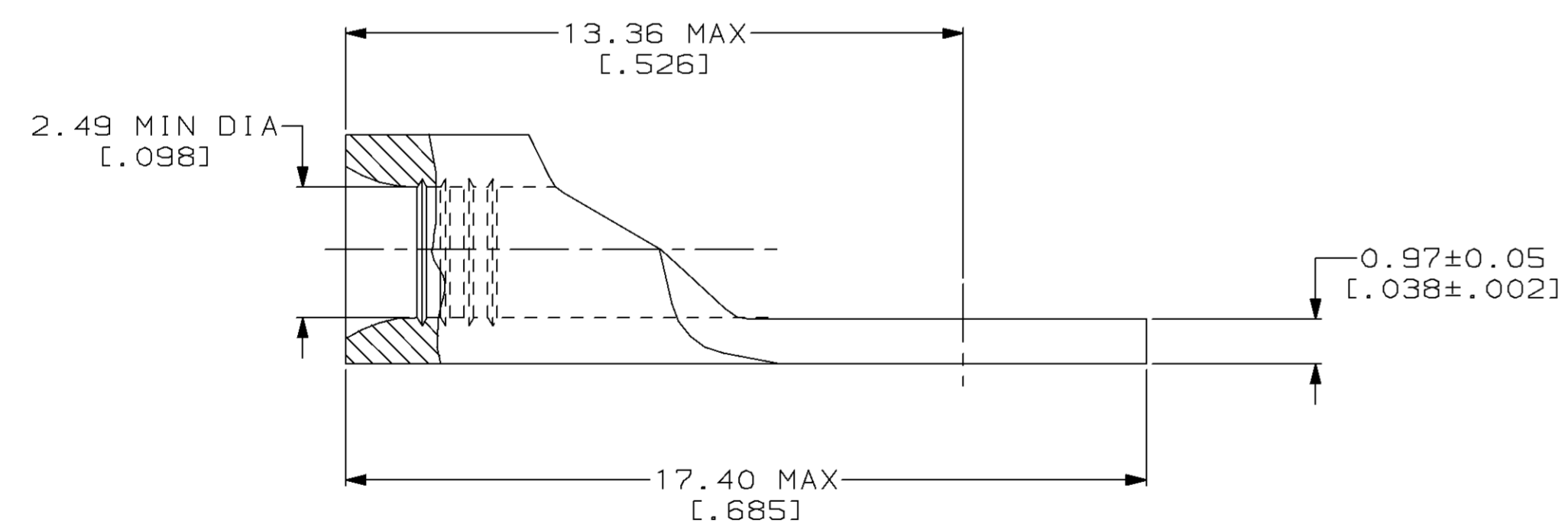

| | | |
|----------|----------------|------------|
| 2500 | ON TAPE | 1-321828-0 |
| ---- | LOOSE PIECE | 321828 |
| QUANTITY | PACKAGING TYPE | PART NO |

| | |
|---|--|
| AMP INCORPORATED CUSTOMER SERVICE SYSTEMS | |
| FOR ADDITIONAL PRODUCT INFORMATION OR COPIES OF DRAWINGS AND TECHNICAL DOCUMENTS | PRODUCT INFORMATION CENTER 1-800-522-6752 |
| FOR APPLICATION TOOLING INFORMATION | TOOLING ASSISTANCE CENTER 1-800-722-1111 |
| FOR ORDER ENTRY | 1-800-526-5142 |

| |
|--|
| MAX RECOMMENDED OPERATING TEMPERATURE: 170°C MAX |
| VOLTAGE RATING: NOT APPLICABLE |
| WIRE CROSS SECTIONAL AREA RANGE: 1.65-4.17mm ² [3,260-8,230] CIR MILS SOLID OR STRANDED |
| THIS DRAWING IS A CONTROLLED DOCUMENT FOR AMP INCORPORATED. IT IS SUBJECT TO CHANGE AND THE CONTROLLING ENGINEERING ORGANIZATION SHOULD BE CONTACTED FOR THE LATEST REVISION. |

| | |
|--|--|
| DO NOT SCALE PRINT. UNLESS SPECIFIED DIMENSIONS IN mm [INCHES] TOLERANCES ON: 2 PLC DEC ± - 3 PLC DEC ± - ANGLES ± - | DR 3-17-93 TA BRINKMAN CHK 3-17-93 DA PATTERSON APPD 3-17-93 DE MILLER APPD 3-17-93 JL MECKLEY PRODUCT SPEC - |
| MATERIAL COPPER PER ASTM B-152 ANNEALED | FINISH TIN PLATE 0.00254 [0.00100] MIN THK PER MIL-T-10727 |

| | | |
|--|--------------------|------------------------|
| AMP AMP Incorporated Harrisburg, PA 17105-3608 | | |
| NAME TERMINAL, RING TONGUE, SOLISTRAND™ | | |
| SIZE Ⓢ | CAGE CODE 00779 | DRAWING NO Ⓢ=321828 |
| SCALE 8:1 | SHEET 1 OF 1 | |